

6

5

4

3

2

1

TYPE	OUTPUT		POLE	TIME RATING	VOLTAGE V	Hz	SYN. SPEED R.P.M
	HP.	kW.					
AMRCED	350	261	6	CONT	460	60	1200

ENCLOSED VENTILATED VERTICAL SOLID SHAFT TYPE, SQUIRREL CAGE ROTOR
NEMA WEATHER PROTECTED TYPE 1

- NOTE:
1. DIMENSIONS IN INCH
 2. FRAME NO.5009
 3. F CLASS INSULATION, S.F. 1.15
 4. FOR DIRECT COUPLING
 5. BEARING SIZE:
UPPER BEARING: 29330+6028 (INSULATED)
LOWER BEARING: 6220C3 [UNINSULATED]
 6. UPPER BEARING IS INSULATED. ANY METAL CONNECTIONS TO IT MUST BE INSULATED.
 7. LUBRICATION:
UPPER BEARING USE OIL.
OIL VISCOSITY: ISO VG68 [300 SSU/100°F]
OIL QUANTITY: 1.8 GAL.
LOWER BEARING USE GREASE. [MOBIL POLYREX EM]
 8. ROTATION: COUNTER-CLOCKWISE [VIEW FROM TOP].
 9. WITH NON-REVERSE RATCHET MECHANISM.
 10. APPROXIMATE WEIGHT: 4050
 11. DOWNTHRUST: 33,800 LBS (L10-8800HRS)
 12. REED FREQUENCY: 29 HZ
 13. SPACE HEATER RATED AT 120 VOLT, SINGLE PHASE, 200 WATTS, LEADS TERMINATE IN MAIN LEAD BOX.

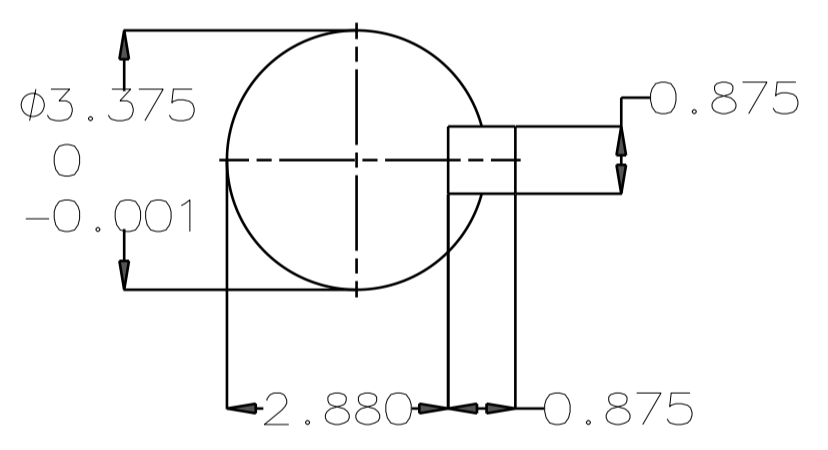
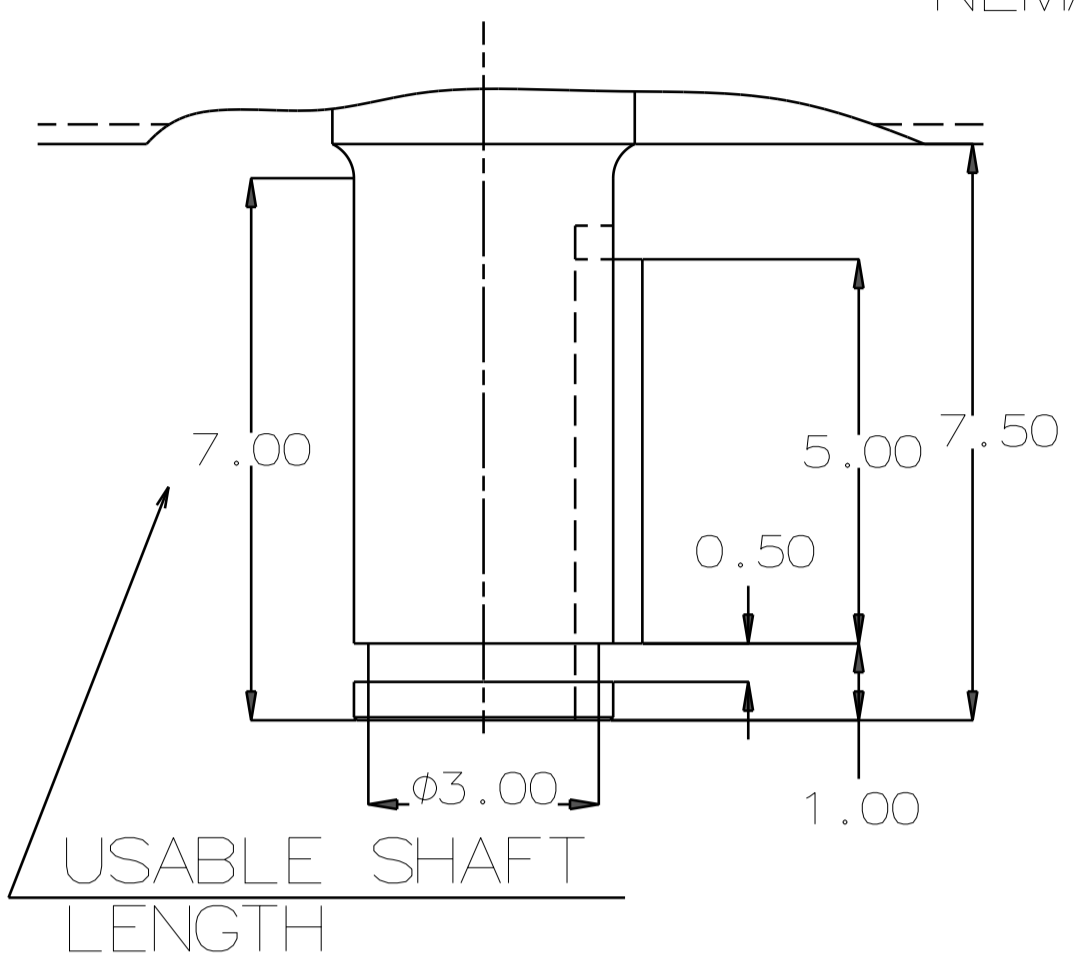

SHAFT END
(ENLARGED VIEW)

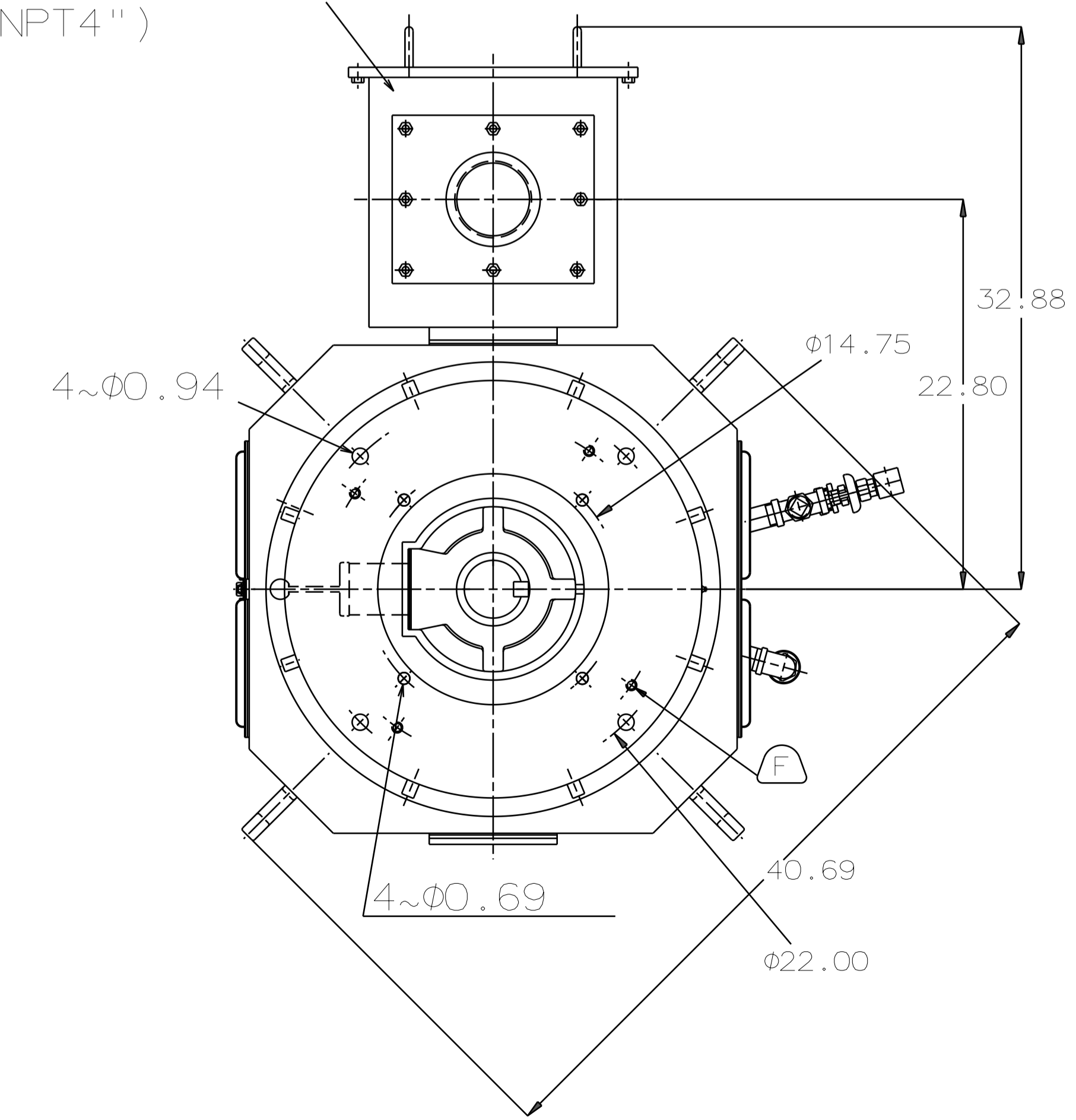
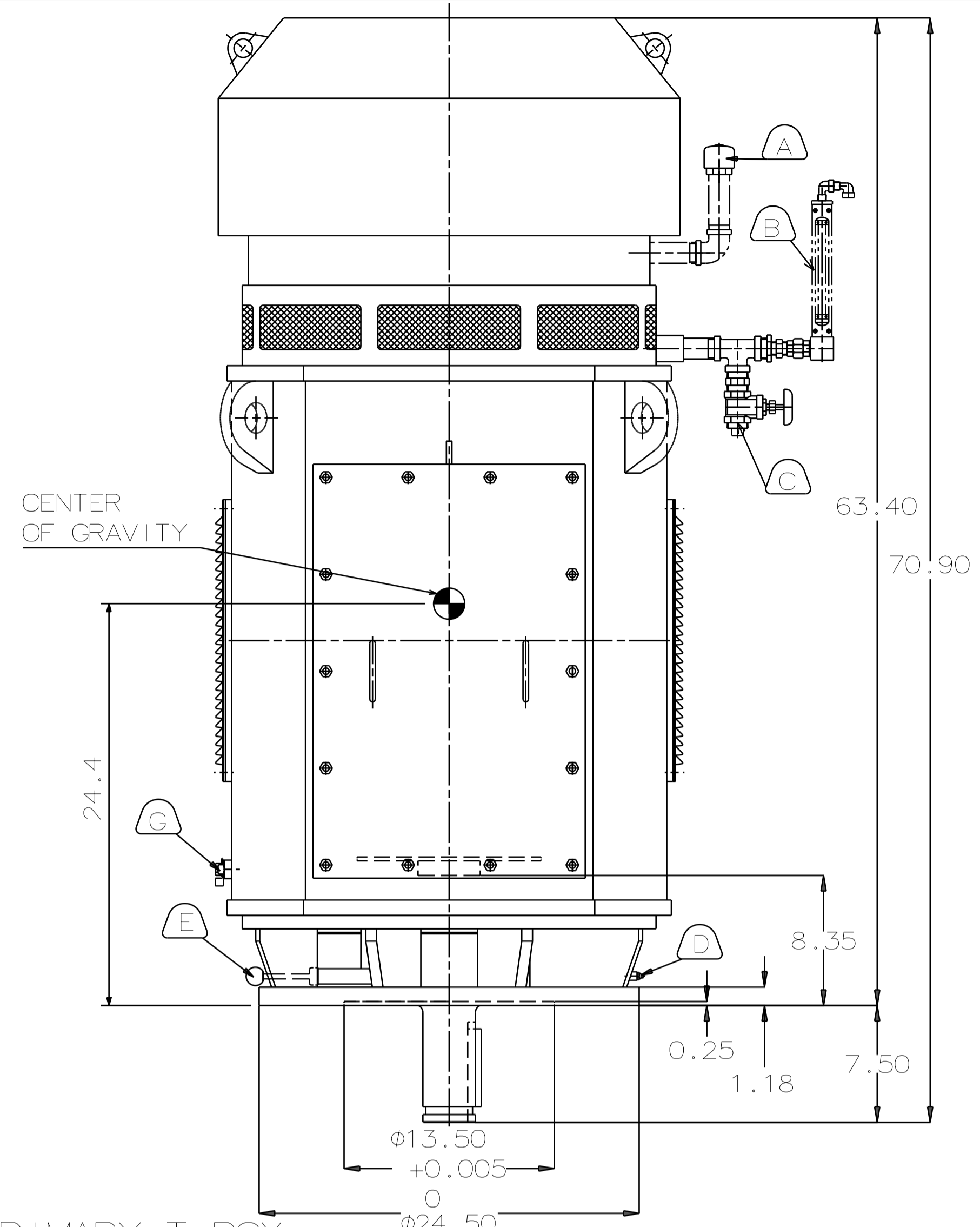

- (A) OIL FILLER [UPPER BEARING]
- (B) OIL GAUGE [UPPER BEARING]
- (C) OIL DRAIN [UPPER BEARING]
- (D) GREASE INLET [LOWER BEARING]
- (E) GREASE DISCHARGER [LOWER BEARING]
- (F) 4~M16 VERTICAL JACKING HOLES, 90°APART IN MOTOR BASE.
- (G) M10 TAPPED GROUNDING ON FRAME, WITH ONE GROUNDING STUDS & [R38-10] TERMINAL LOCATED AS SHOWN.

DATE	DEC 08 2016	OUTLINE DIMENSIONS	
	VSP3506	3-PHASE INDUCTION MOTOR	
DWG NO.	4B040L300	REV:00	

DWN.	C.FU	MAY.11.2015
CHKD.	R.LEE	MAY.11.2015
APPD.	C.LIU	MAY.11.2015



6

5

4

3

2

1